

-  Clean water
-  Domestic use
-  Civil use



### PERFORMANCE RANGE

- Flow rate up to **160 l/min** (9.6 m<sup>3</sup>/h)
- Head up to **56 m**

### INSTALLATION AND USE

Designed to transfer clean water free from abrasive particles and liquids that will not damage the pump's components.

Reliable and easy to operate, these pumps have extensive application in domestic and civil settings, particularly for distributing water with small to medium-sized pressure tanks, transferring fluids, and watering orchards and gardens.

※ **The AISI 304 stainless steel impeller comes with a ten-year guarantee**

### ELECTRIC MOTOR

Equipped with cutting-edge electric motors, the three-phase pumps are designed to work with inverters, offering stable and noiseless performance.

They feature efficiency class **IE3** for three-phase motors and **IE2** for single-phase motors, bolstered by class F insulation and IPX4 protection.

### APPLICATION LIMITS

- Manometric suction head up to **7 m**
- Liquid temperature between **-10 °C** and **+90 °C**
- Ambient temperature up to **+40 °C**
- Maximum working pressure:
  - **6 bar** for CP 100-130-132-150-158
  - **10 bar** for CP 170-190-200

### AVAILABLE UPON REQUEST

- ✘ Mechanical seal options available
- ✘ Protection rating IP X5 for CP 170, CP 170M
- ✘ Different voltage requirements 60 Hz frequency

### PATENTS - TRADE MARKS - MODELS

- CPm158 registered trademark no. 0001516350
- Registered community model no. 002098434

**CURVES AND PERFORMANCE DATA – HS=0 m**

**50 Hz**

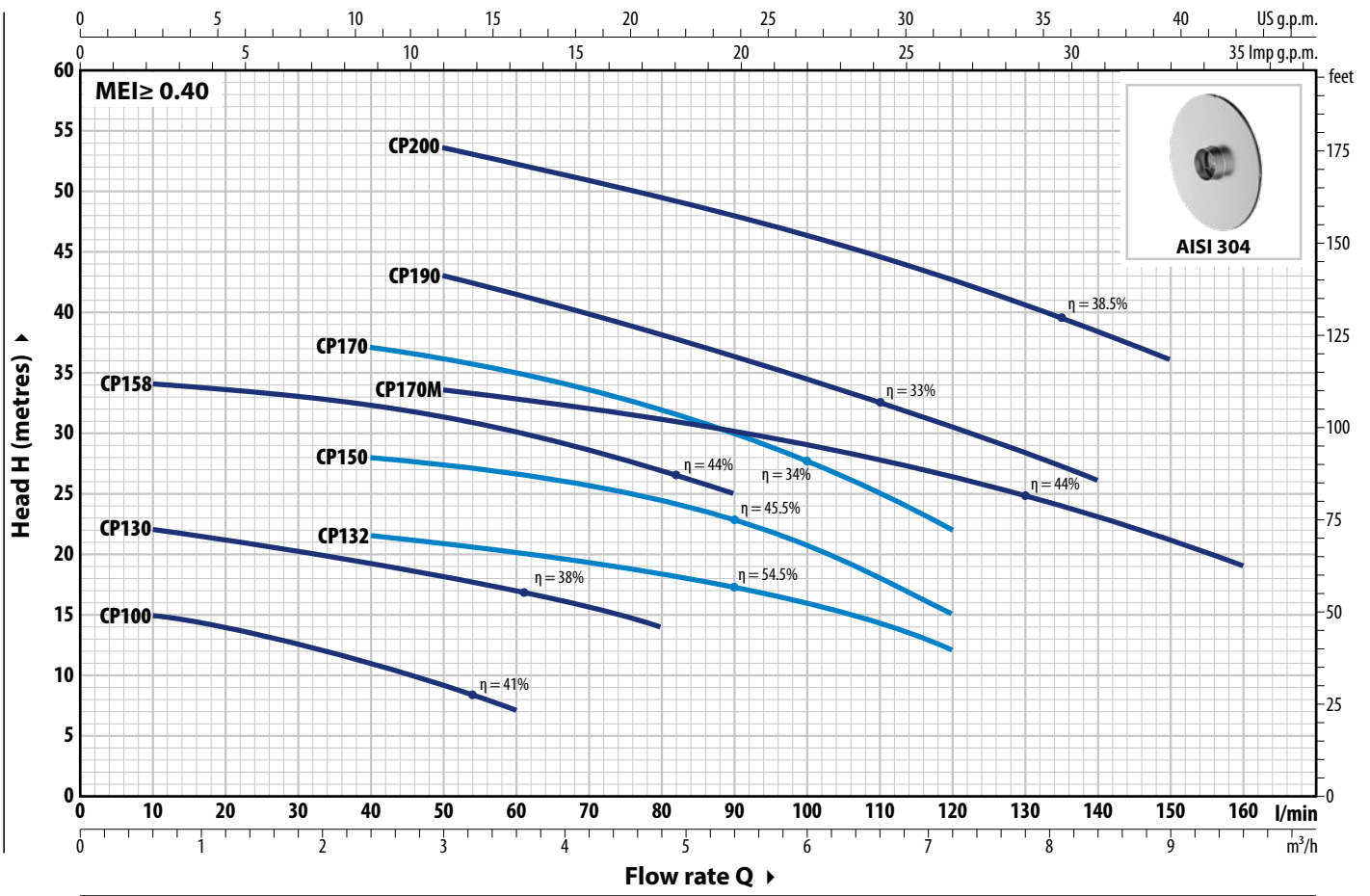

TYPE		POWER (P <sub>2</sub> )		1~3~	Q	m <sup>3</sup> /h																		
Single-ph.	Three-ph.	kW	HP			0	0.6	1.2	1.8	2.4	3.0	3.6	4.2	4.8	5.4	6.0	6.6	7.2	7.8	8.4	9.0	9.6		
						0	10	20	30	40	50	60	70	80	90	100	110	120	130	140	150	160		
CPm 100	CP 100	0.25	0.33	IE2 IE3	H metres	16	15	14	12.5	11	9	7												
CPm 130	CP 130	0.37	0.50			23	22	21	20	19	18	17	15.5	14										
CPm 132	CP 132	0.55	0.75			23	-	22.5	22	21.5	21	20.5	19.5	18.5	17.5	16	14	12						
CPm 150	CP 150	0.75	1			29.5	-	29	28.5	28	27.5	26.5	26	24.5	23	21	18	15						
CPm 158	CP 158	0.75	1			36	34	33.5	33	32.5	31.5	30	28.5	27	25									
CPm 170	CP 170	1.1	1.5			41	-	-	38	37	36	35	33.5	32	30	27.5	25	22						
CPm 170M	CP 170M	1.1	1.5			36	-	-	35	34.5	33.5	33	32	31	30	29	28	26.5	25	23	21	19		
CPm 190	CP 190	1.5	2			48	-	-	46	44.5	43	41.5	40	38	36	34.5	32.5	30.5	28	26				
CPm 200	CP 200	2.2	3			56	-	-	55	54.5	53.5	52	51	49.5	48	46	44.5	42.5	40.5	38.5	36			

Q = Flow rate H = Total manometric head HS = Suction height

Performance curves comply with EN ISO 9906 Grade 3B tolerance limits.

### ABSORPTION

TYPE	VOLTAGE
<b>Single-phase</b>	<b>230 V</b>
CPm 100	1.9 A
CPm 130	3.2 A
CPm 132	3.9 A
CPm 150	5.7 A
CPm 158	6.0 A
CPm 170 - 170M	7.8 A
CPm 190	11.0 A
CPm 200	13.0 A

TYPE	VOLTAGE	
	230 V - $\Delta$	400 V - $\text{Y}$
<b>Three-phase</b>		
CP 100	1.6 A	0.95 A
CP 130	2.0 A	1.15 A
CP 132	2.2 A	1.3 A
CP 150	4.2 A	2.4 A
CP 158	4.3 A	2.5 A
CP 170 - 170M	5.2 A	3.0 A
CP 190	7.4 A	4.3 A
CP 200	9.3 A	5.4 A

### DIMENSIONS AND WEIGHT

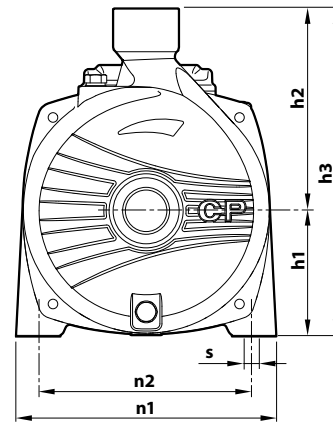
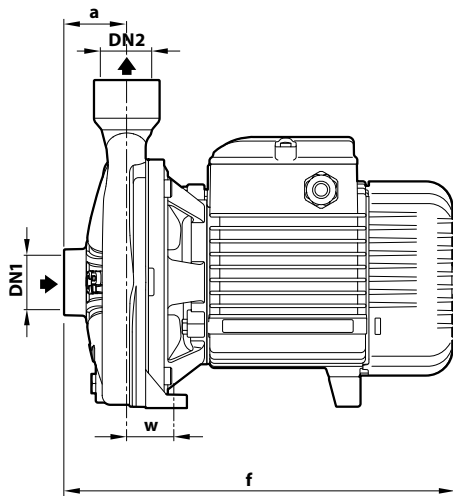

TYPE		PORTS		DIMENSIONS mm									kg	
Single-ph.	Three-ph.	DN1	DN2	a	f	h3	h1	h2	n1	n2	w	s	1~	3~
CPm 100	CP 100	1"	1"	42	257	205	82	123	165	135	38	11	7.0	7.0
CPm 130	CP 130												7.8	7.8
CPm 132	CP 132												8.5	8.5
CPm 150	CP 150												12.3	12.2
CPm 158	CP 158												12.4	12.3
CPm 170	CP 170	1 1/4"	1"	51	367	260	110	150	206	165	44.5	11	19.1	17.6
CPm 170M	CP 170M												19.3	17.9
CPm 190	CP 190												21.6	21.5
CPm 200	CP 200												24.6	24.6
				47.5	364	290	115	175	242	206	36.5			
				384	24.6								24.6	

### PALLET CAPACITY

TYPE		NO. OF PUMPS
Single-ph.	Three-ph.	
CPm 100	CP 100	96
CPm 130	CP 130	96
CPm 132	CP 132	96
CPm 150	CP 150	70
CPm 158	CP 158	70
CPm 170	CP 170	50
CPm 170M	CP 170M	50
CPm 190	CP 190	36
CPm 200	CP 200	36

## CONSTRUCTION FEATURES

**1 Pump body** Cast iron with cathaphoresis treatment with ISO 228/1 threaded ports

**2 Cover** **AISI 304** stainless steel (cast iron for models CP 170-170M-190-200)

**3 Impeller** Stainless steel **AISI 304**

4 Mechanical seal	Pump	Seal	Shaft	Materials
	CP 100-130-132	<b>AR-12</b>	Ø 12 mm	Ceramic / Graphite / NBR
	CP 150-158	<b>AR-14</b>	Ø 14 mm	Ceramic / Graphite / NBR
	CP 170-170M-190-200	<b>FN-18</b>	Ø 18 mm	Graphite / Ceramic / NBR

**5 Motor shaft** Stainless steel **AISI 431**

**6 Electric motor** **CPm**: single-phase 230 V - 50 Hz with winding integrated thermal motor protection.  
**CP**: three-phase 230/400 V - 50 Hz  
 ※ Pumps are equipped with high-efficiency motors (IEC 60034-30-1)  
     class **IE2** for single-phase models  
     class **IE3** for three-phase models  
 Continuous running duty **S1**

